

Product: KLUDI L-INE single lever sink mixer DN 10

Ref.: 428140577

Product description

single lever sink mixer DN 10
 solid lever
 single hole mounted
 flow class Z
 PCA Cache aerator M 16,5 x l
 ceramic cartridge with hot water safety device
 swivelling spout (360°)
 rapid installation set
 flexible high pressure supply tubes G 3/8
 noise group I

Finishes:
 05 chrome

Advertisement

- * KLUDI GmbH & Co KG KLUDI L-INE sink mixer item no. 428140577
- ** ceramic cartridge with hot water safety device Ø 35 mm, DIN EN 817
- *** chrome plated brass, DIN 50930-6

sink mixer, manufacturer KLUDI GmbH & Co KG KLUDI L-INE sink mixer item no. 428140577, DN 10, finishes: chrome, type: sink mixer DN 10, swivel spout, solid lever, lever projection 85 mm, PCA Cache aerator M 16,5 x l, noise level DIN EN 4109 group I, report no. P- IX, flow class Z (max. 0,14 l/s), nozzle projection 210 mm, rapid installation set, flexible high pressure supply tubes 3/8 inch with metal body with DVGW / KIWA / WRAS / CSTB length 350 mm, nozzle height 275 mm, ceramic cartridge with hot water safety device Ø 35 mm, overall length 300 mm, for borehole diameter Ø 32 mm, for pressure type water heater, for continuous line heater, PN 10,

Product picture



Dimensional drawing

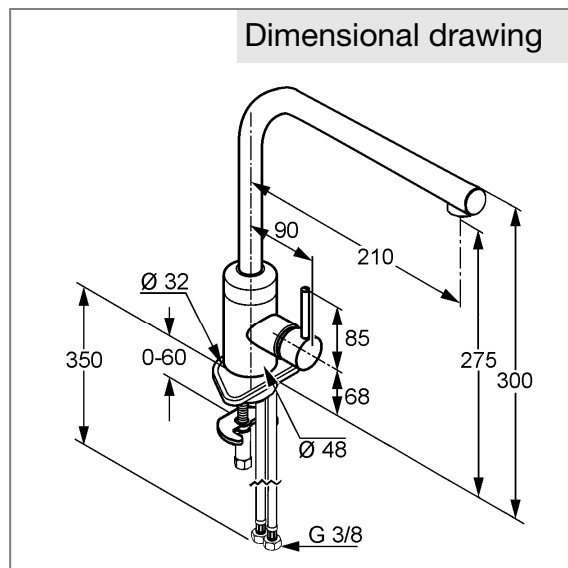

Flow rate diagram

